

CARVEWRIGHT

W O O D W O R K I N G S Y S T E M

Replacing the Z-Motor Pack

To remove and replace the Z-motor pack you will need the following tools:

- 4mm Allen wrench
- #2 Phillips screwdriver (magnetic tip preferred)

Removing the Z-motor pack.

1. **Ready the machine.** Unplug the machine from the power outlet and place it on a stable work platform. Raise the head up several inches and move the Y-truck to the left side of the machine for best access.

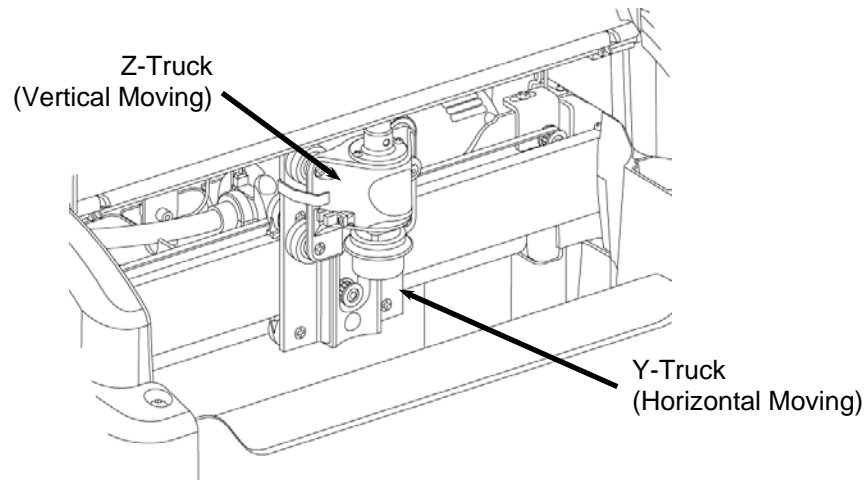

FIGURE 1: VIEW OF THE Z-TRUCK

2. **Ready the flexshaft for removal from the Z-truck.** Move the Z-truck to the very top of its travel (until it reaches the hard stop) so that the flexshaft support tube protrudes from the head cover (See Figure 2).

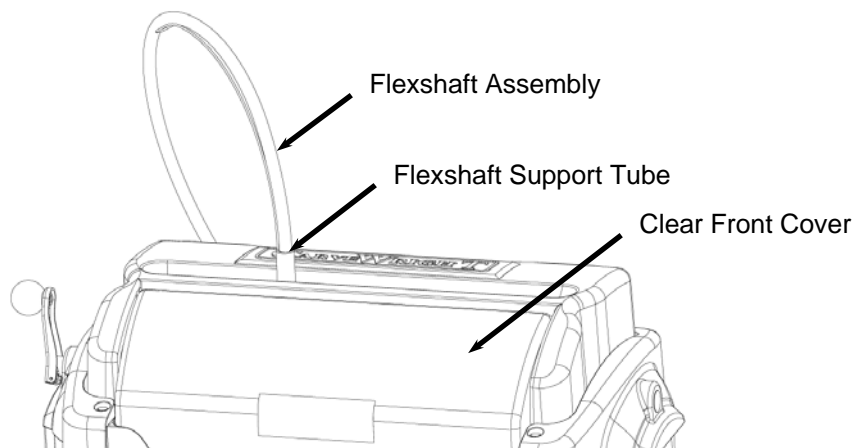

FIGURE 2: EXTERIOR VIEW OF THE FLEXSHAFT AND HEAD COVERS

3. **Detach the flexshaft from the top of the Z-truck.** The flexshaft assembly is retained by a ball detent located in the flexshaft receptacle (See Figure 3). Firmly grasp the flexshaft support tube while reaching under the clear front cover with your other hand to grab the Z-truck. Pull up firmly on the flexshaft support tube and twist slightly while bracing the Z-truck. **DO NOT PULL ON THE SHEATH.** The flexshaft will pop out of the detent. Wrap the end of the flexshaft in tape so that the core will not fall out and lay the detached flexshaft end to the side.

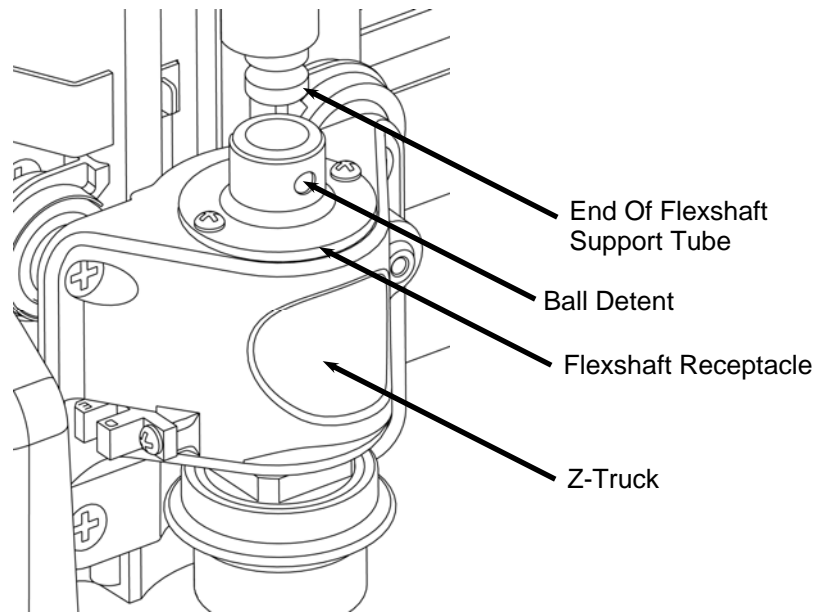

FIGURE 3: VIEW OF THE FLEXSHAFT CONNECTION TO THE Z-TRUCK

4. **Remove the machine cover screws.** Remove the four cover screws as shown in Figure 4 with the #2 Phillips screwdriver. Use a magnetic tipped screwdriver if possible to avoid dropping the screws into the machine.

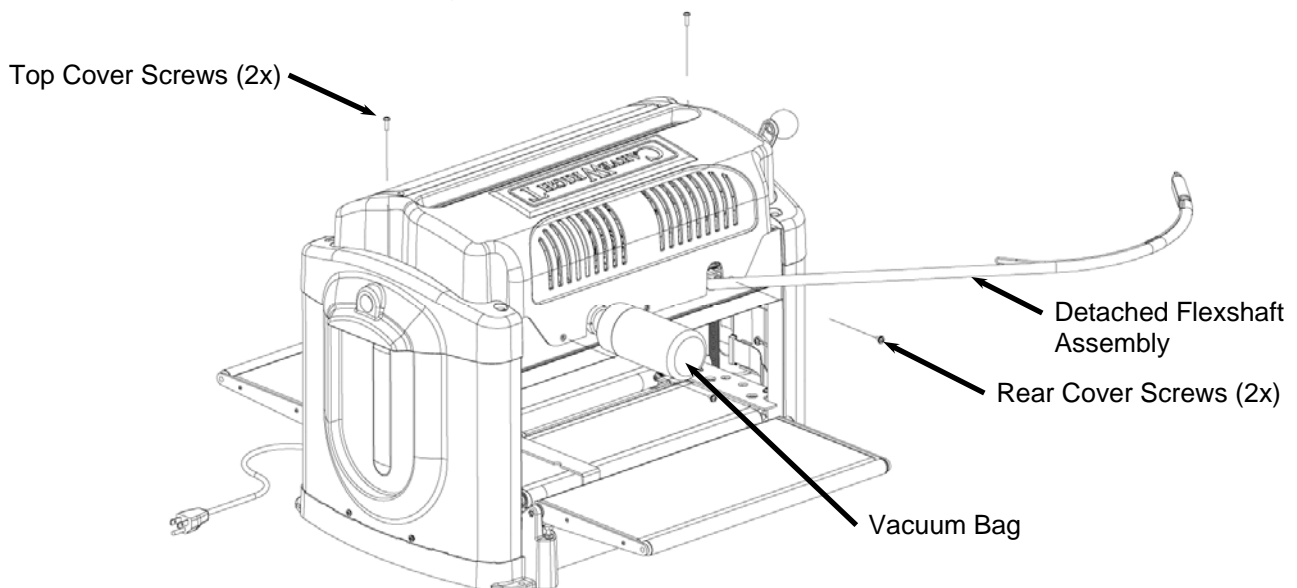

FIGURE 4: EXPLODED VIEW OF THE COVER SCREWS

- Detach the cover and locate the cover cables.** Lift the cover straight up and locate the two cables still connecting it to the head. On the side nearest the AC cut motor you will see the cable that connects the cover interrupt switch. For this repair we want to avoid disconnecting this cable if possible. If for some reason you have to disconnect this cable to entirely remove the head cover, you will need to locate and disconnect the two bullet connectors at the back of the AC motor. In most machines you will need to remove the screw in the small plastic enclosure to access the two bullet connectors. On the opposite side you will see the 8-wire head cover cable harness (terminated with a 10-pin connector).

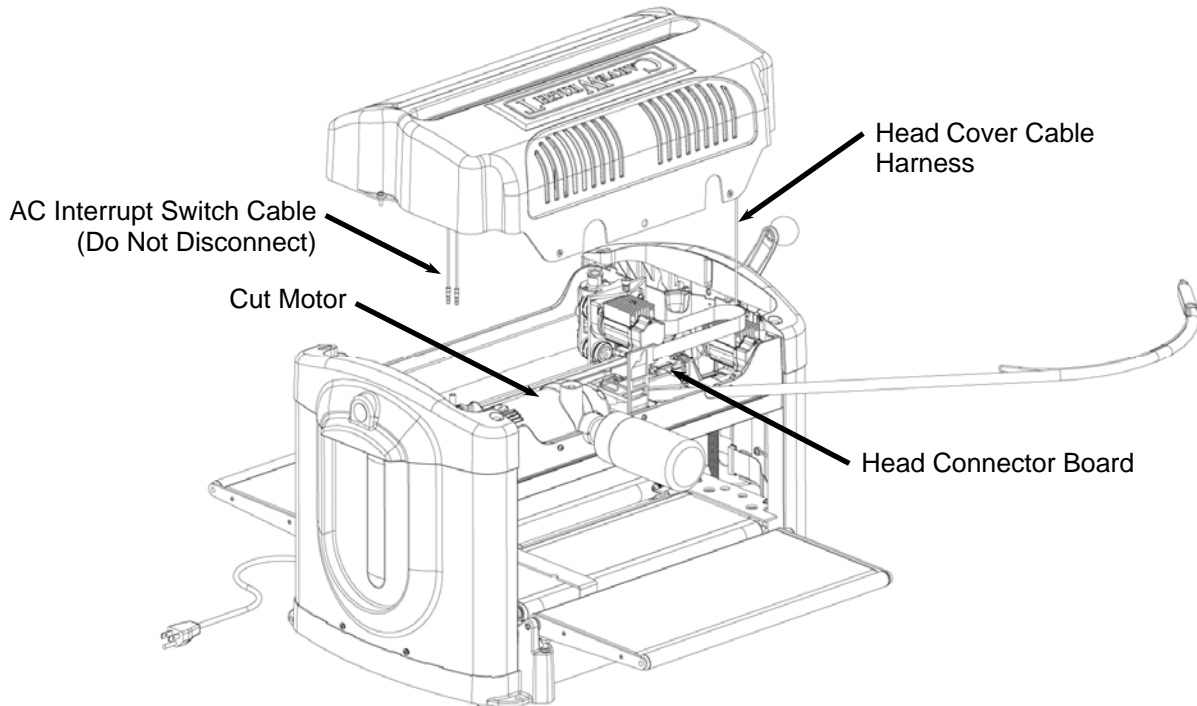

FIGURE 5: EXPLODED VIEW OF THE LIFTED COVER

- Unplug the head cover cable at the head connector board attached just to the left of the Y-drive motor pack.** The location of this connector on the connector board will vary depending on the machine's production date (See Figure 7). You may have to reach underneath the head to unplug the cable. Notice how the cable is routed along side and under the Y-truck motor pack. This routing is important to remember when re-assembling the cover.

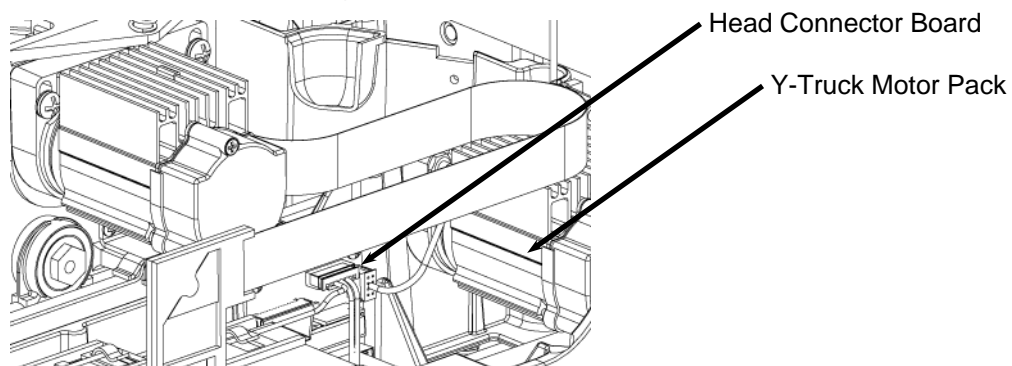

FIGURE 6: LOCATING THE HEAD CONNECTOR BOARD

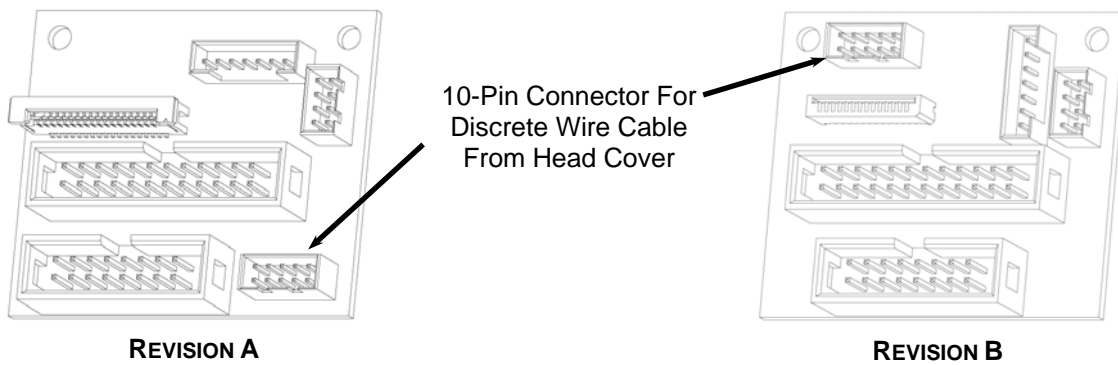

FIGURE 7: LOCATION OF CONNECTOR FOR HEAD COVER CABLE FOR THE EARLIER REVISION A AND LATER REVISION B MACHINES

- Lay the head cover to the side.** With the AC Interrupt Switch Cable still connected, carefully lay the cover onto the back outfeed tray (See Figure 8). Make sure to avoid pulling on the cable during the rest of the repair. You can also lay the cover over the side as shown in **Picture 1** of Appendix A.

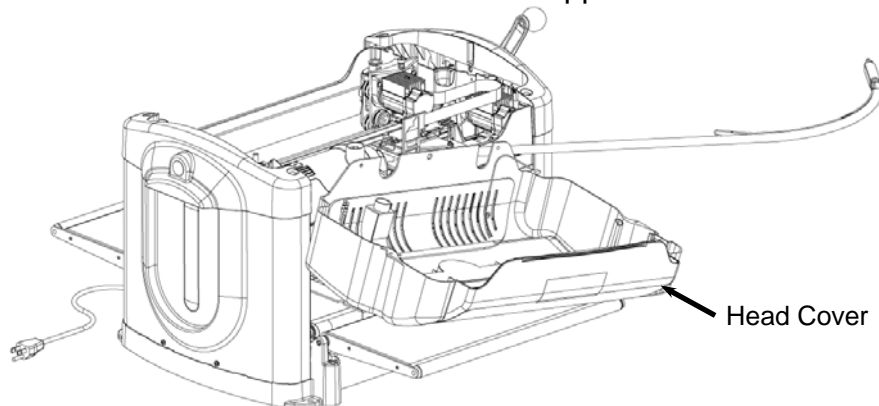

FIGURE 8: EXPLODED VIEW OF THE REMOVED COVER

- Detach the FFC cable guard.** Unplug the 8-wire cable coming from the Z-motor pack from the slot in the FFC cable guard. Remove the screw holding the FFC cable guard.

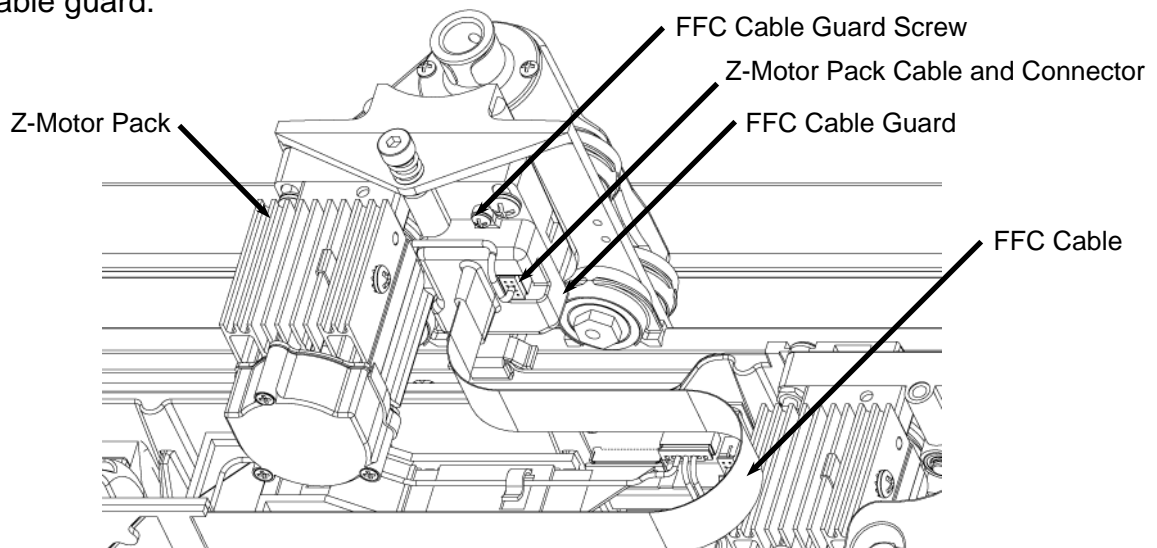

FIGURE 9: VIEW OF THE BACK OF THE Z-MOTOR PACK

9. **Disconnect the FFC cable.** Slide the FFC cable guard along the FFC Cable to expose the FFC cable connector on the electronics board. Unplug the FFC cable from the connector. It may be glued in place so take care in pulling it straight out. Lay the cable to the side out of the way.

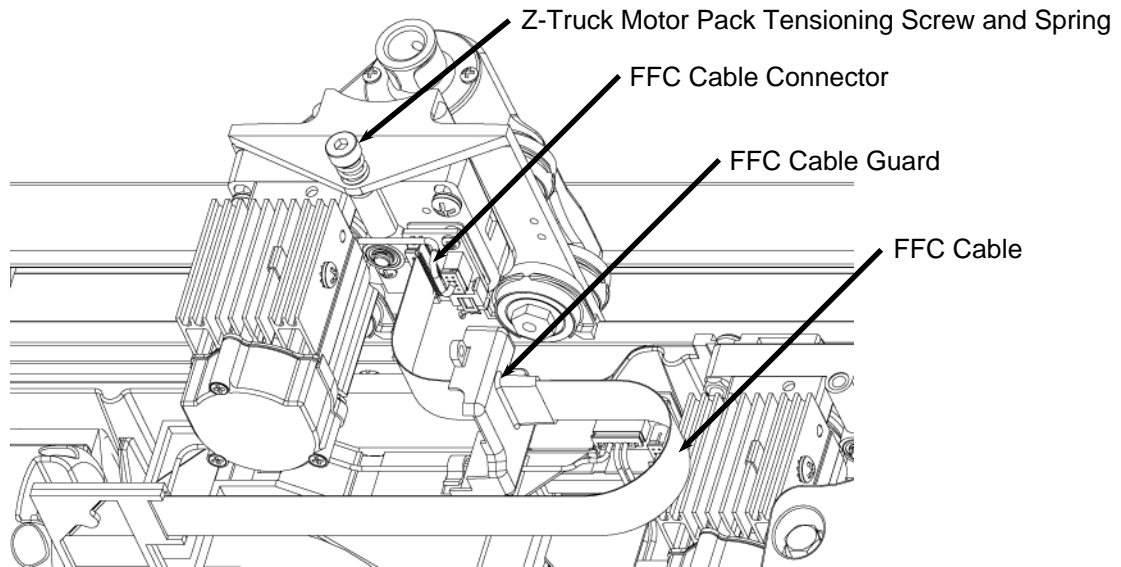

FIGURE 10: VIEW OF THE BACK OF THE Z-MOTOR PACK

10. **Disconnect the Board Sensor cable.** Disconnect the 4-wire board sensor cable from the connector directly below the vertical FFC cable. Pull the connector straight down to disconnect. It may also be glued in place so take care in pulling it straight out.

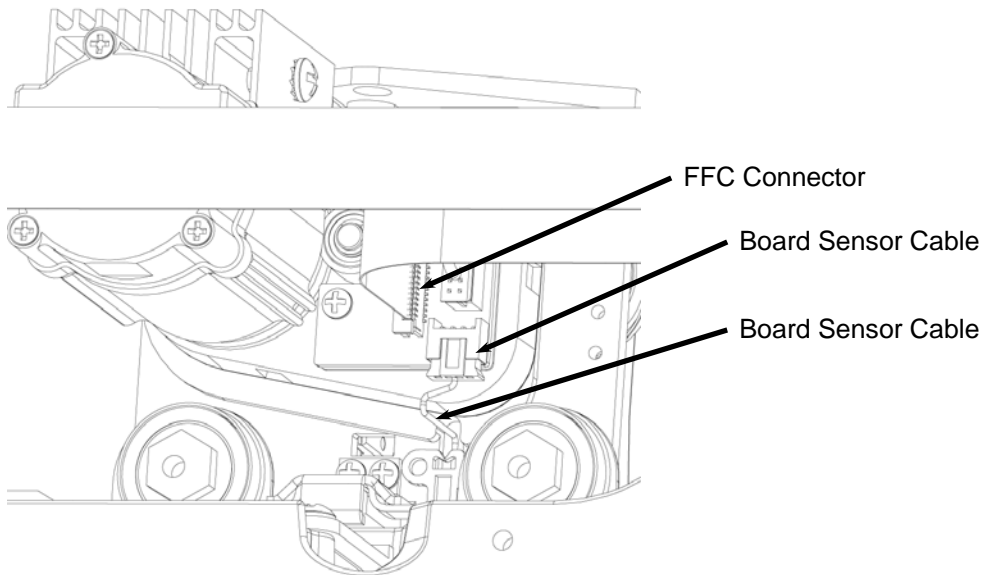

FIGURE 11: VIEW OF THE Z-MOTOR PACK ELECTRONICS

- 11. Remove the Z-truck motor pack.** Once the FFC and board sensor cables are disconnected, remove the Z-truck motor pack tensioning shoulder screw and spring with the 4mm Allen wrench. Next, remove the two screws (with lock washers) securing the motor pack onto the Y-truck. Remove the Z-truck motor pack from the machine. You will have to slip the belt off the pulley in the front of the Y-truck to fully disengage the assembly.

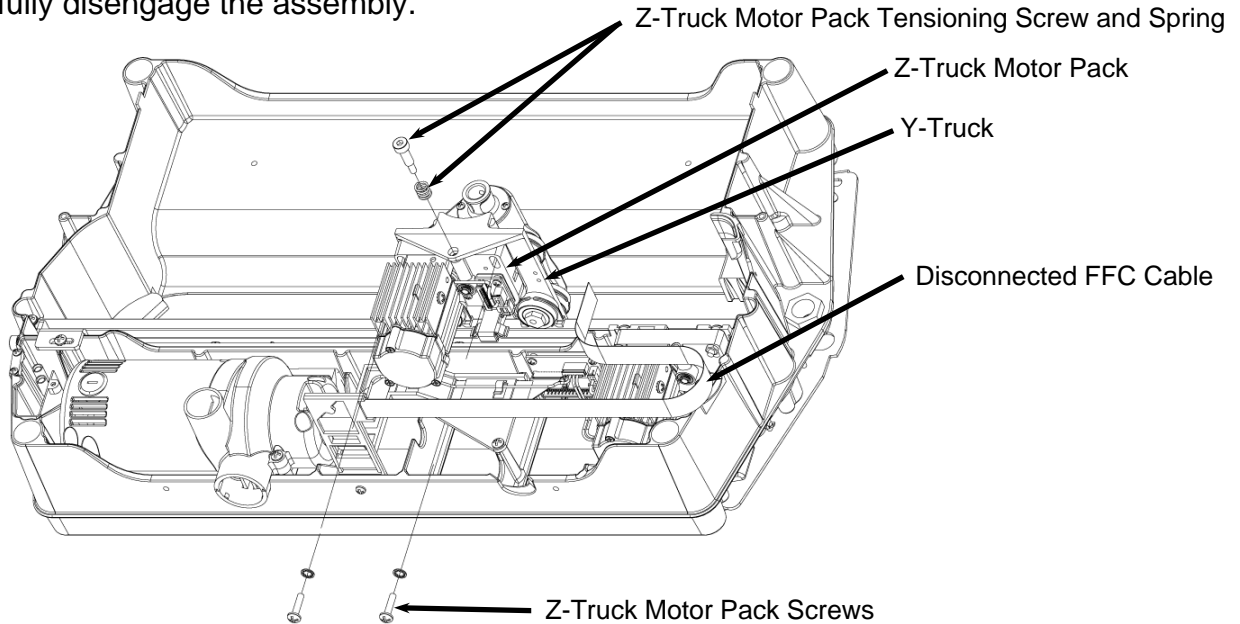

FIGURE 12: VIEW OF THE Z-TRUCK MOTOR PACK REMOVAL

Re-assembling the Z-truck motor pack

- 1. Re-assemble the new Z-motor pack.** Insert the protruding belt pulley on the Z-motor pack through the slot in the Y-truck and into the top loop of the Z-truck belt. Replace and fully tighten the Z-truck motor pack tensioning shoulder screw and spring with the 4mm Allen wrench (See Figure 12).

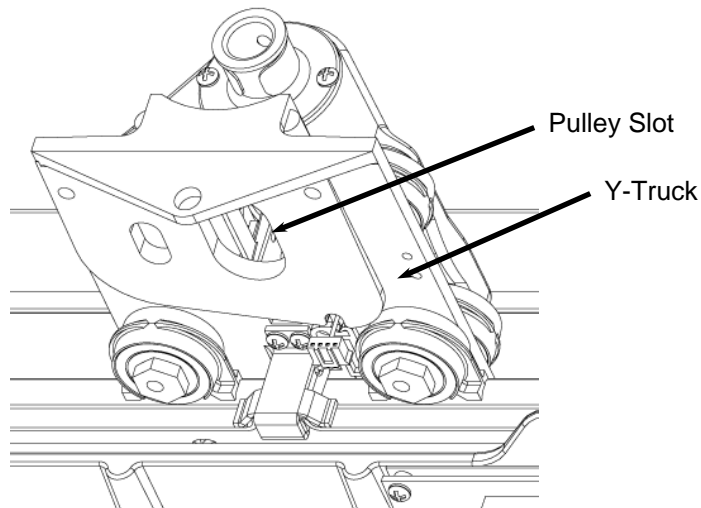

FIGURE 13: BACK OF THE Y-TRUCK

2. **Assemble the screws holding the Z-truck motor pack.** Replace and tighten the two screws (with lock washers) that secure the Z-truck motor pack to the Y-truck (See Figure 12). Tighten these two screws as tight as possible by hand. Check again and make sure that the Z-truck motor pack tensioning shoulder screw and spring are in place and tight before tightening these screws fully with a screwdriver. Failing to tighten these screws **AFTER** the Z-truck motor pack tensioning shoulder screw is tightened will result in an incorrect belt tension. Also make sure that all wires are clear of the area. It is possible to pinch the wires coming up from the board sensor when this interface is tightened.

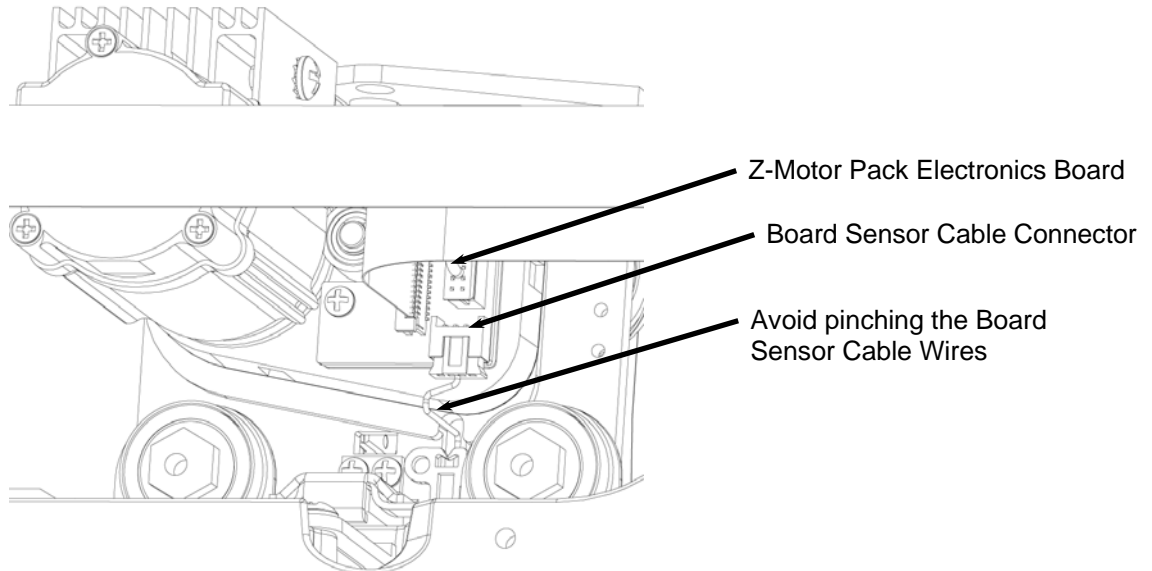

FIGURE 14: VIEW OF THE BACK OF THE Y-TRUCK

3. **Test the Z-Truck travel.** Move the Z-truck up and down along its entire travel feeling for jerky or noisy motion. If the motion is not smooth the belt is not tensioned correctly or the motor pack gears may need to be adjusted.
4. **Plug in the board sensor cable:** Insert the 4-wire board sensor cable into its respective connector on the Z-motor pack electronics board.
5. **Re-assemble the FFC cable guard.** Slide the FFC cable guard onto the free end of the FFC cable with the screw hole pointing up.
6. **Plug in the FFC cable and secure the FFC cable guard.** Plug the FFC cable into the FFC connector on the Z-motor pack electronics board. Be careful to protect the FFC cable at all times from nicks or bends. Slide the cable guard down and secure it to the motor pack with the single screw.
7. **Test the assembled Z-truck.** Move the tightened Z-truck up and down along its entire travel range. The Z-truck should move smoothly and quietly along the rails.
8. **Replace the head cover.** There are several important steps and checks needed as you replace the head cover.

- a. Move the Y-truck all the way to the left side of the machine and make sure that the FFC cable does not drag on the Y-truck heatsink (See Figure 15). If the FFC cable is dragging bend it upwards so that it consistently clears the heatsink.
- b. Make sure that the blow deflector is correctly placed. If it is out of place the board sensor can quickly become covered in dust and inoperable and/or the Z-truck will hit the blow deflector and stall. The deflector sits over the edge of the head casting and lines up with the air tube in the cover when assembled. Also see **Picture 2** in Appendix A.

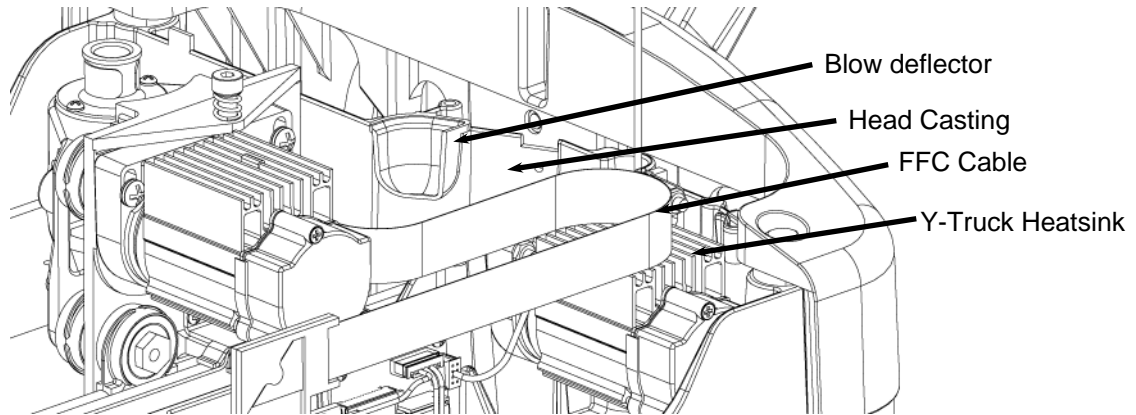

FIGURE 15: PLACEMENT OF THE BLOW DEFLECTOR - ISO

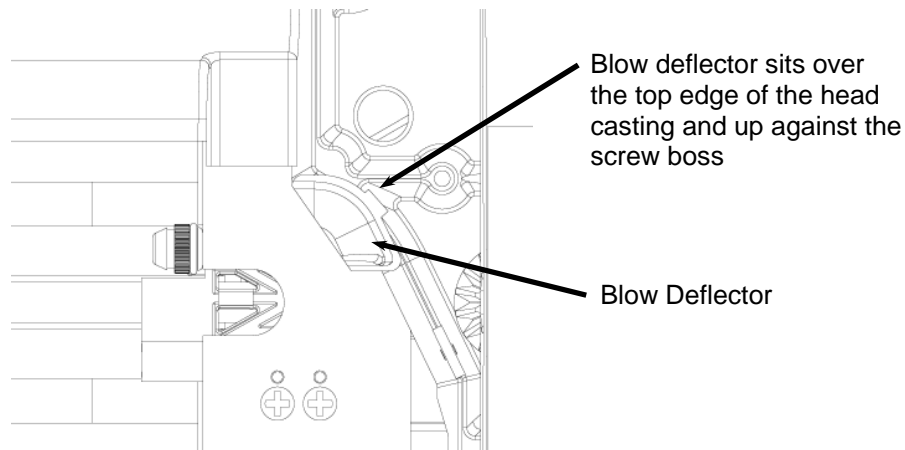

FIGURE 16: PLACEMENT OF THE BLOW DEFLECTOR - TOP

Route the Head Cable Harness down between the wall of the head casting and the side of the Y-motor pack, under the Y-motor pack and plug it into the connector board as shown in Figure 17. Make sure that the connector is oriented correctly using the keying ribs and slots before plugging it in. Note that the white wire will be oriented toward the non-keypad side of the machine.

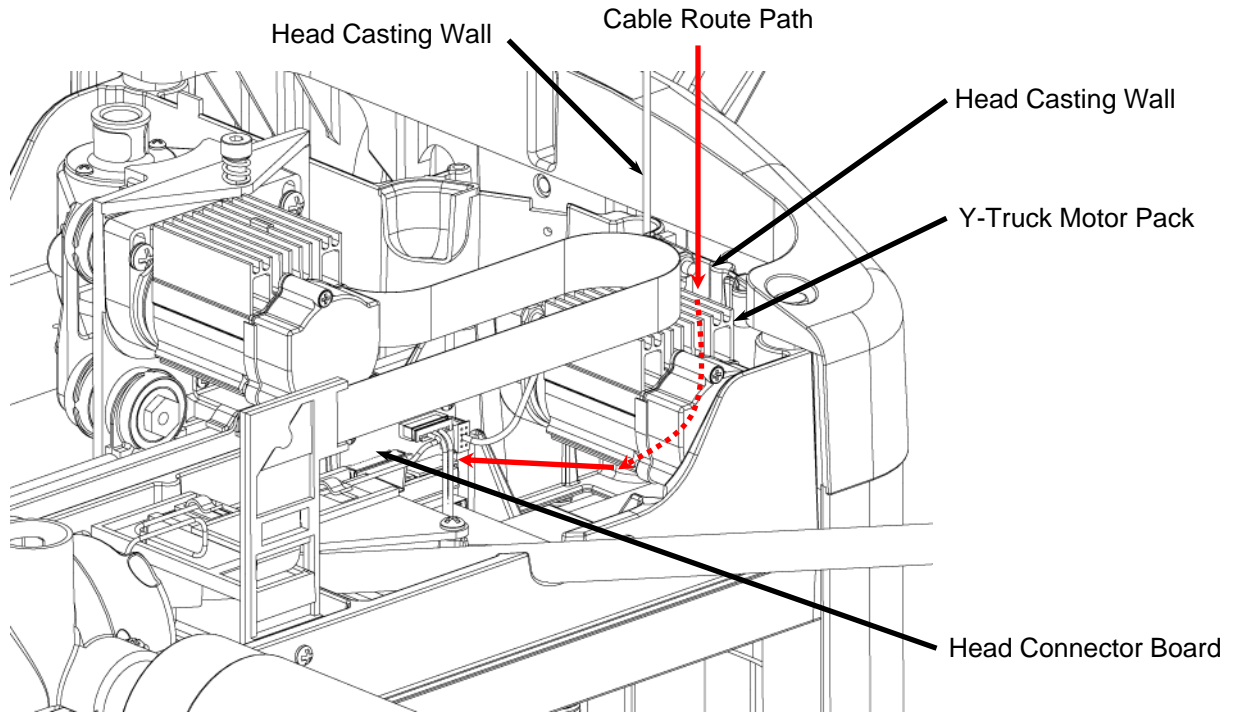

FIGURE 17: ROUTING THE HEAD CABLE HARNESS

- c. Gently lift and replace the head cover onto the head making sure that the FFC cable, the AC Interrupt Switch Cable, and the Head Cable Harness are not pinched.

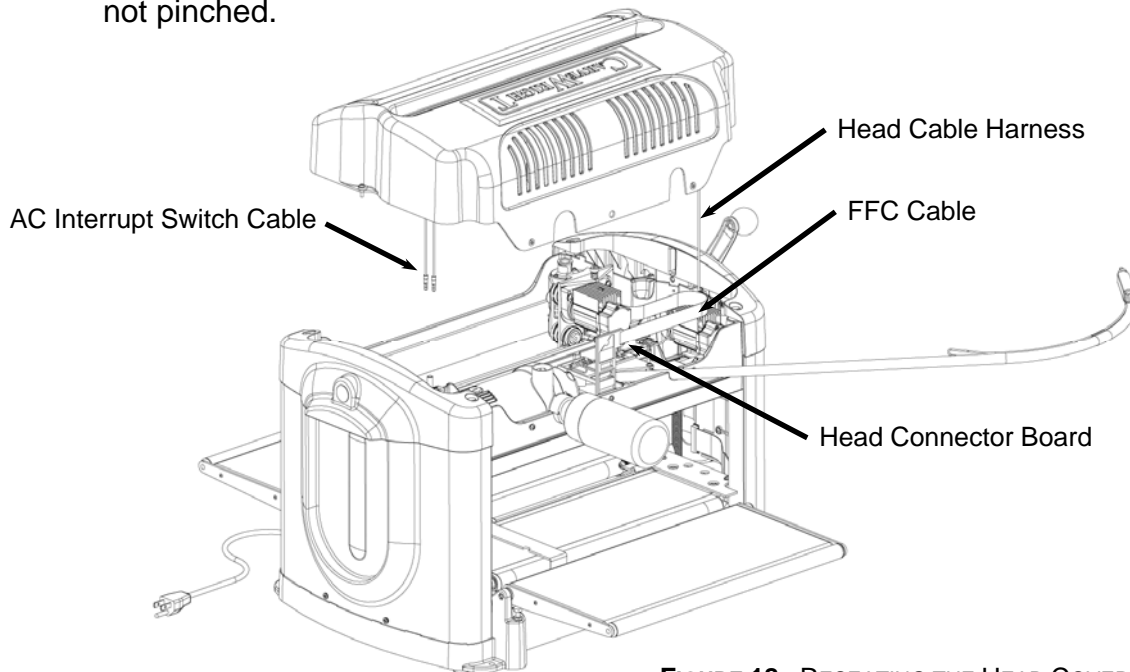

FIGURE 18: RESEATING THE HEAD COVER

- d. Once the head cover is placed back onto the head you will need to reseat the wire harness retainers in the correct locations before replacing the screws.

These retainers should be attached to the cables themselves and keep the cables confined to certain areas. In some machines there will be one on both cables, but on most machines you will only find one on the Head Cable Harness. You will have to reach in from the front of the machine to access them. Make sure that the retainers are placed over the edge of the head casting and under the edge of the cover. Make sure that they do not prevent the head cover from setting flat. See **Picture 3** and **Picture 4** in Appendix A for further clarification.

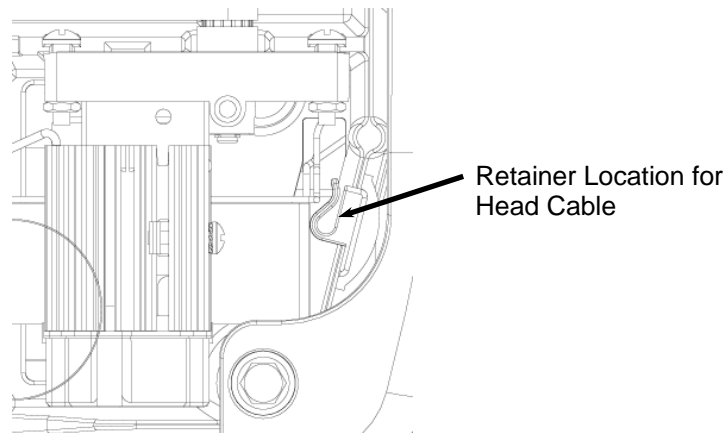
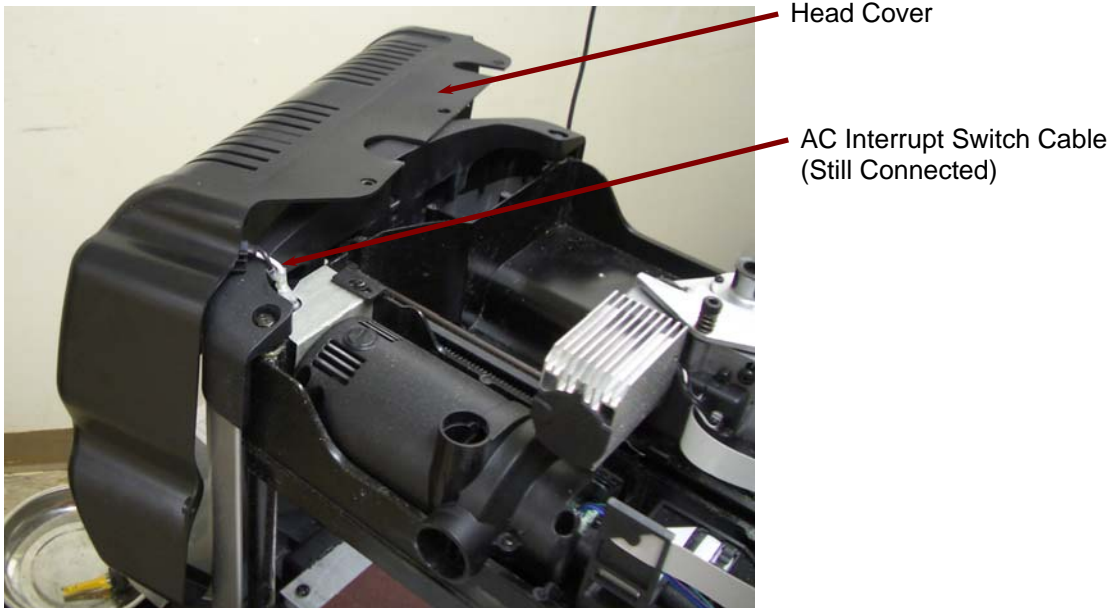

FIGURE 19: LOCATING THE HEAD CABLE HARNESS RETAINER

- e. Replace the four screws as shown in Figure 4. The two long screws go in the vertical locations.
 - f. Verify that the head cover is laying flat on the head. Verify that the blow deflector is lined up with the vertical blow port located in the head. Verify that the FFC cable does not drag on the Y-motor heatsink when the Z-truck is pushed all the way to the left hand side.
9. **Prepare the flexshaft assembly for re-insertion into the machine.** Gently pull the protruding flexshaft core (with squared end) out of the sheath several inches. Push the core back into the sheath and make sure that it slips into, and engages, the cutting motor. It will drop into the receptacle on the motor side about 5/8ths of an inch. Turn the core by hand and feel for resistance of the motor. If the shaft spins without resistance, push the core inward while rotating until it drops into the slot and engages the motor.
10. **Insert the flexshaft into cutting head.** Looking through the slot in the top cover, locate the flexshaft receptacle on the top of the Z-truck. Inside the receptacle there is a square recess that mates with the exposed square end of the flexshaft core. Turn the chuck on the bottom of the cutting head (open the safety cover for access) until the square core end can be inserted into the recess. Press the flex shaft all the way down into its receptacle. A click will be heard and felt as the shaft snaps into place.

Appendix A



PICTURE 1: LAYING THE HEAD COVER OVER THE SIDE OF THE MACHINE

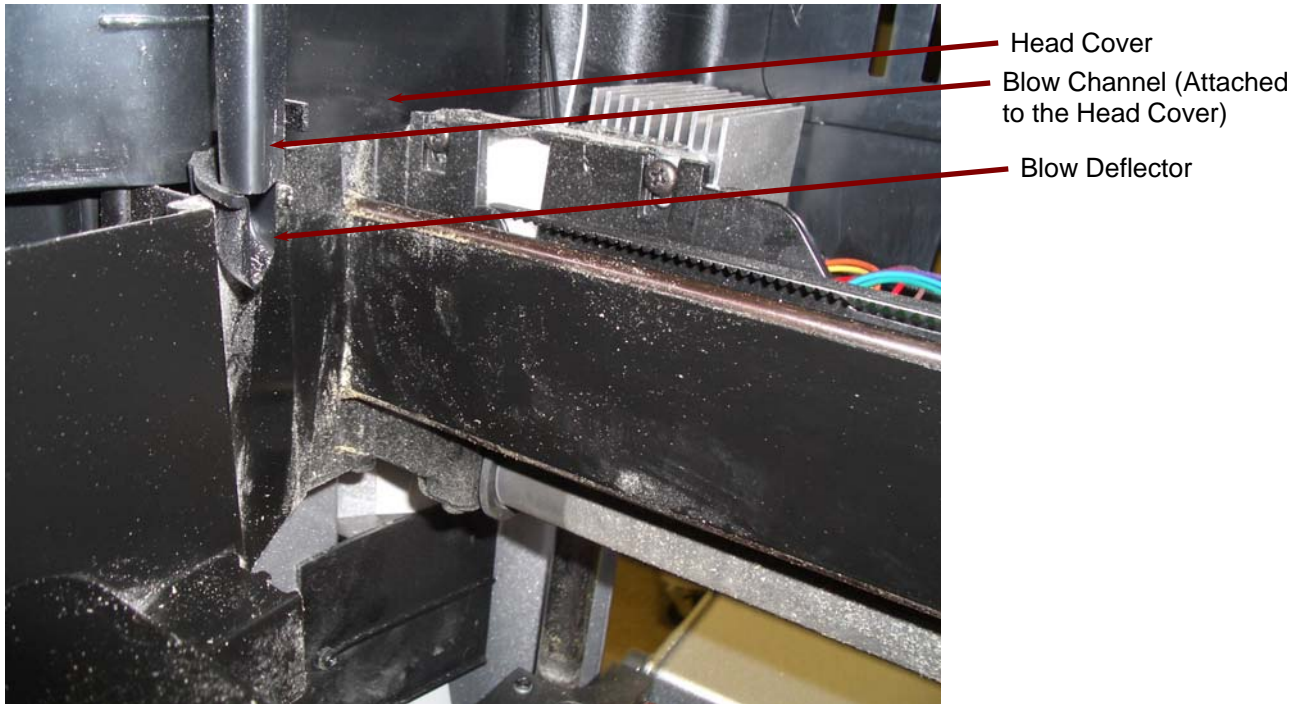

PICTURE 2: LOCATION OF THE BLOW DEFLECTOR

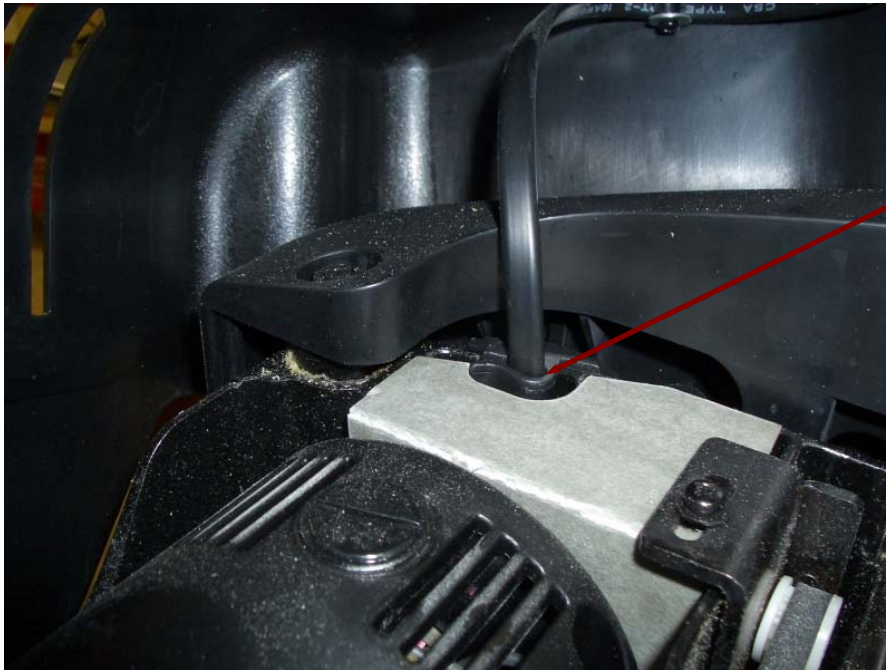

Wire Retainer
(AC Motor Side)

PICTURE 3: LOCATION OF AC INTERRUPT SWITCH CABLE WIRE RETAINER

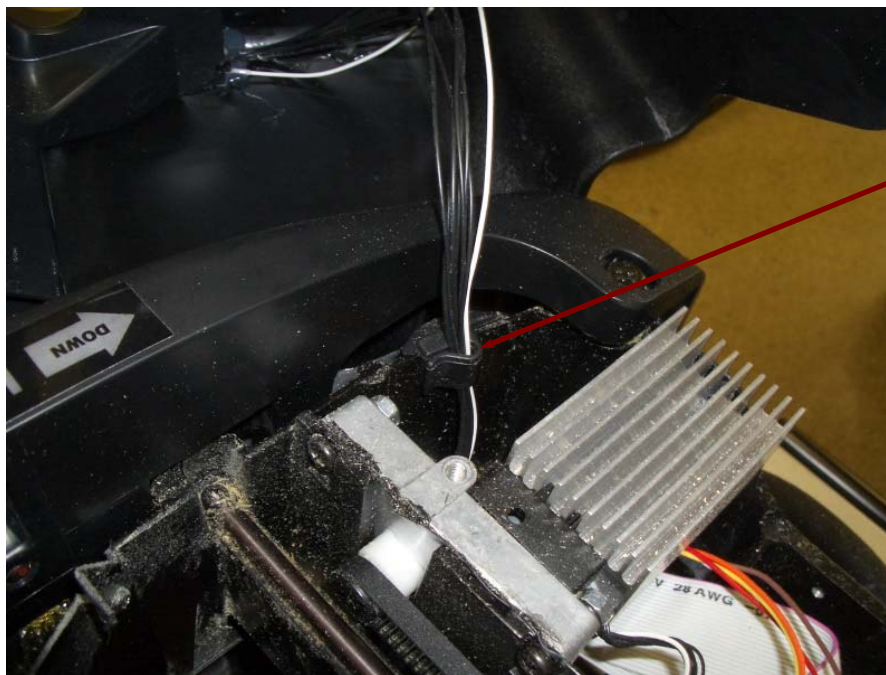

Wire Retainer

PICTURE 4: LOCATION OF HEAD CABLE HARNESS WIRE RETAINER