

Adjusting the Head Pressure

Checking the head pressure and adjusting the vertical guide rods is part of the machine set-up process. The head pressure should also be checked periodically during routine maintenance. There are several reasons that the head pressure may be low.

- Insufficient lubrication on the vertical guide rods or the vertical leadscrews.
- Misalignment in the vertical guide rods.
- Poor mesh on the gears that drive the vertical leadscrews.

Please refer to the *Troubleshooting* section of your Operators Manual for the procedure for checking the head pressure and lubricating the vertical guide rods. The proper head loading should be between 75 and 85 pounds.

If lubricating the vertical guide rods does not resolve the low head pressure reading, then you will want to realign them. The vertical guide rods are located at the four corners of the machine and are the rails upon which the head of the machine rides up and down. If these vertical guide rods are shifted out of alignment the head may bind when lowered, and the pressure put on the workpiece by the head may be too low for optimum operation. These vertical guide rods can be knocked out of alignment during shipping or when the machine is moved.

In order to adjust the vertical guide rods you will need the following tools:

- #2 Phillips screwdriver or power drill with #2 screw bit
- 10mm socket, socket wrench, and 3" extension

1. **Ready the machine.** Unplug the machine from the power outlet and place it on a stable work platform. Raise the head up several inches for best access. Move the Z-truck to the very top of its travel (until it reaches the hard stop) so that the flexshaft support tube protrudes from the head cover (See Figure 1).

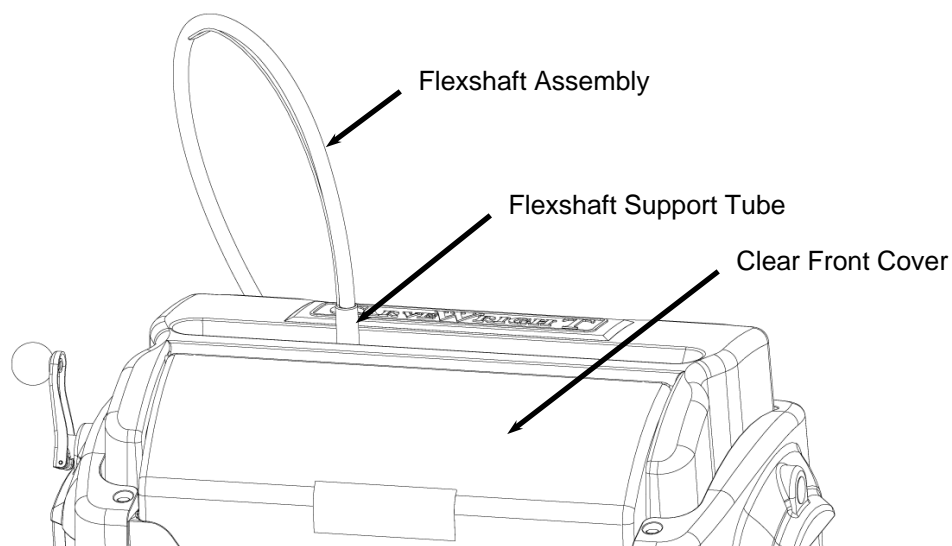

FIGURE 1: EXTERIOR VIEW OF THE FLEXSHAFT AND HEAD COVERS

2. **Detach the flexshaft from the top of the Z-truck:** The flexshaft assembly is retained by a ball detent located in the flexshaft receptacle (See Figure 2). Firmly grasp the flexshaft support tube while reaching under the clear front cover with your other hand to grab the Z-truck. Pull up firmly on the flexshaft support tube and twist slightly while bracing the Z-truck. **DO NOT PULL ON THE SHEATH.** The flexshaft will pop out of the detent. Wrap the end of the flexshaft in tape so that the core will not fall out and lay the detached flexshaft end to the side.

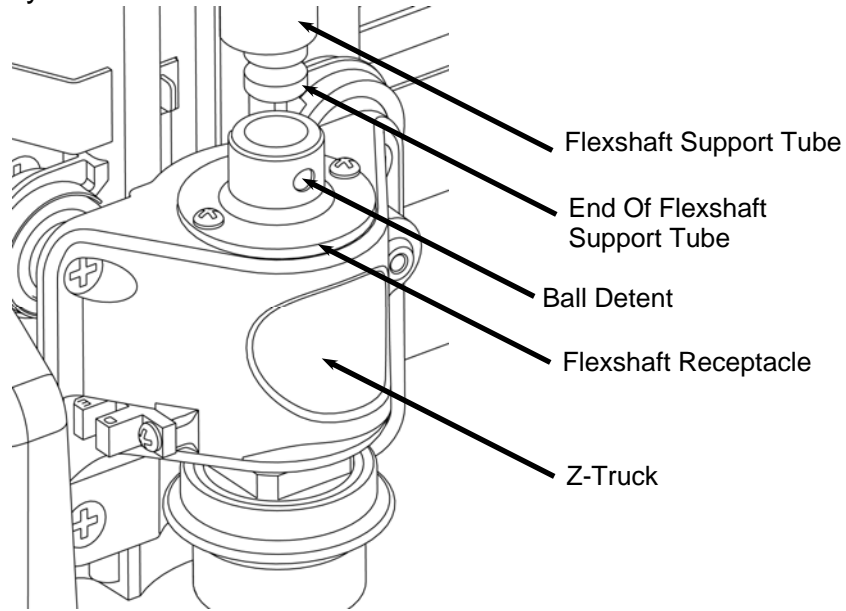

FIGURE 2: VIEW OF THE FLEXSHAFT CONNECTION TO THE Z-TRUCK

3. **Remove the bottom cover.** Carefully lay the machine on its back with the dust collection port facing down. Remove the 12 screws securing the black sheet metal cover onto the base (four of which are located in the rubber feet) and remove it.

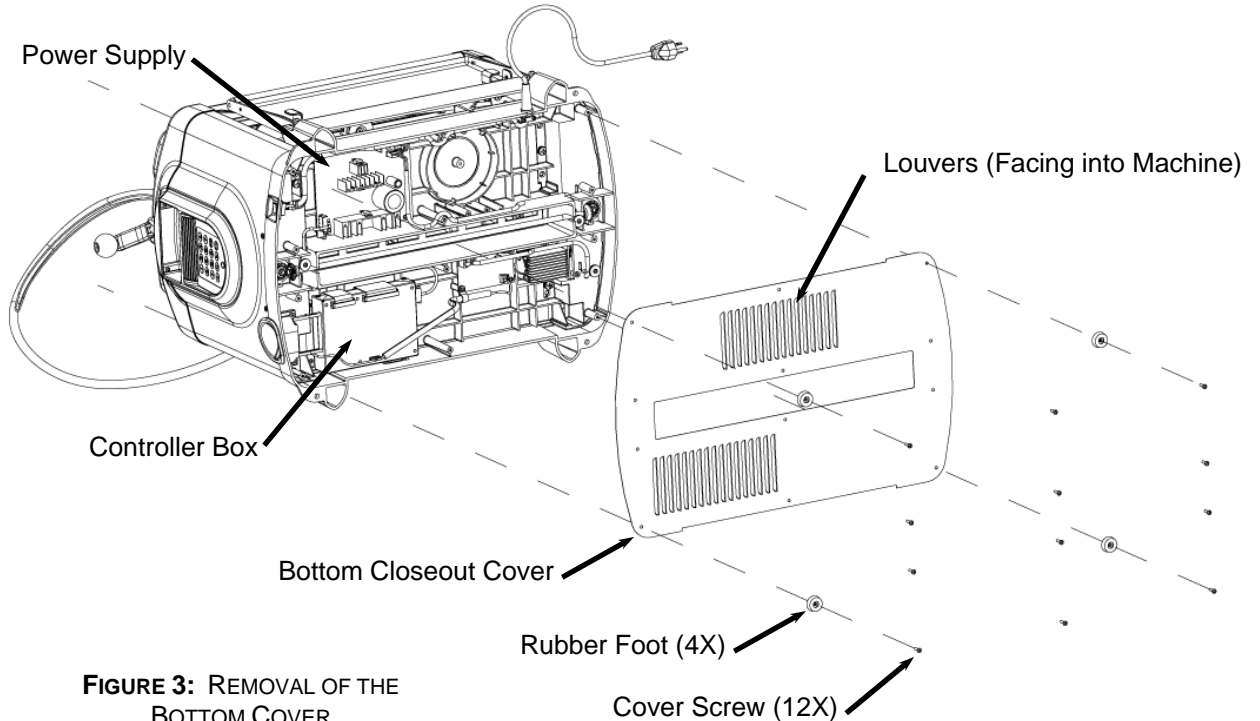

FIGURE 3: REMOVAL OF THE BOTTOM COVER

4. **Check to see if the tie rod between the two leadscrews has sufficient play.** While the machine is still on its back, locate the leadscrew tie rod. This tie rod (with bevel gears) connects the two leadscrews on either side of the machine. The leadscrews drive the head up and down as the crank handle is turned. Grab the tierod and verify that there is side to side play in the rod. The amount of play will vary between machines, but the important thing to note is that there is some side to side play. The play should be minimal but apparent. If the rod is locked side to side turn the crank handle one full turn and try again. If the rod is still locked in place please contact CarveWright technical support (713-473-6572) for additional instructions.

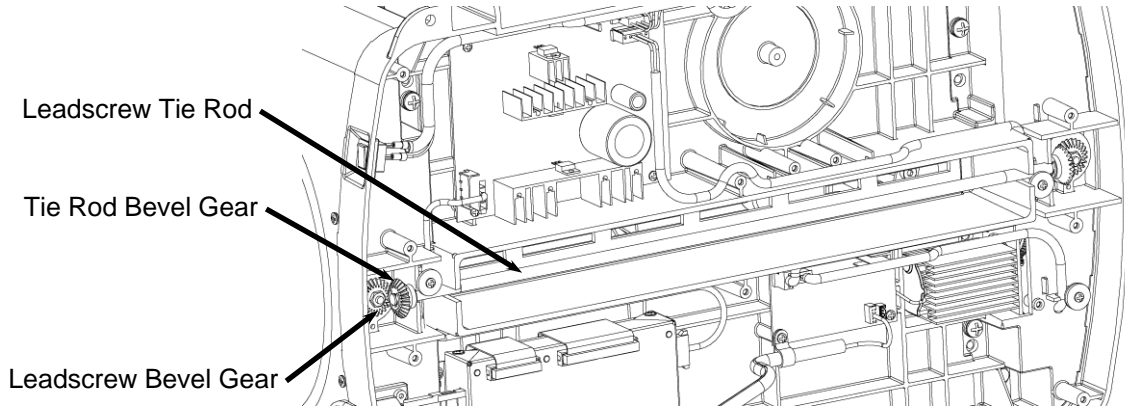

FIGURE 4: LOCATION OF THE LEADSCREW TIE ROD

5. **Return the machine to its upright position.** Be careful to not pinch any of the base cables between the casting and the table. Crank the head down to within 1" of the sandpaper belts.
6. **Loosen the screws securing the top of the four vertical guide rods.** Using a 10mm socket, loosen all four bolts attaching the vertical guide rods to the top of the side panels. **LOOSEN 1 to 2 TURNS ONLY - DO NOT REMOVE SCREWS.**

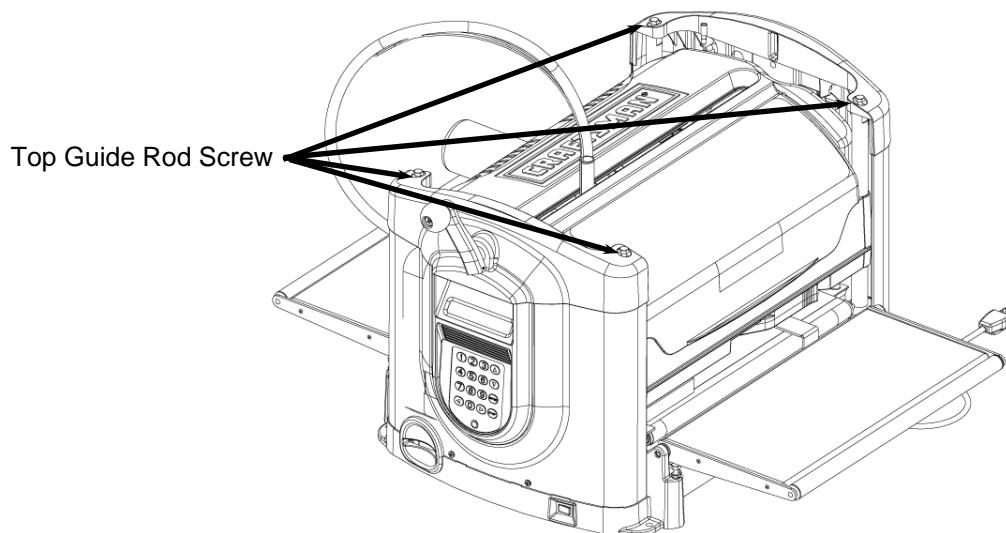

FIGURE 5: LOCATION OF TOP VERTICAL GUIDE ROD SCREWS

7. **Loosen one set of bottom screws securing the vertical guide rods.** Slide one end of the machine 4 inches off the edge of the bench. It does not matter if it is the side with the keypad or the side without. This will give you sufficient room to reach to screws attaching the bottom of the vertical guide rods to the base of the machine on the overhanging side (see Figure 6). Loosen both screws attaching the bottom of the vertical guide rods to the base of the machine with the 10mm socket. **LOOSEN 1 to 2 TURNS ONLY - DO NOT REMOVE SCREWS.** Now all four screws (top and bottom) attaching the two vertical guide rods on the overhanging side are loose. This allows the head to naturally set the correct spacing for these two guide rods.

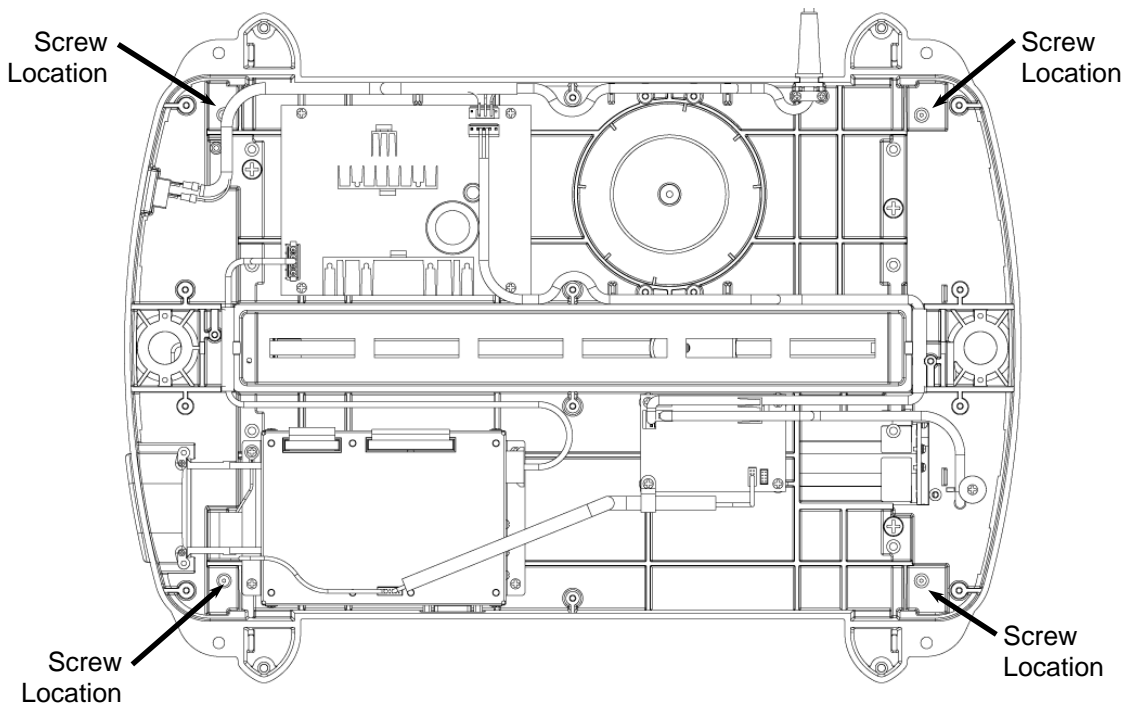

FIGURE 6: LOCATION OF BOTTOM VERTICAL GUIDE ROD SCREWS

8. **Tighten the two bottom screws.**
9. Rotate machine 180 degrees to where the other side of the machine is overhanging the bench. Repeat **Step 8-9** for this side of the machine.
10. **Tighten the screws securing the vertical guide rods:** Crank head up to approximately the center of travel and tighten the four top 10mm bolts.
11. **Re-check head pressure using the procedure used in the *Troubleshooting* section of your *Operators Manual*.** If the head pressure still reads low, please contact CarveWright technical support (713-473-6572) for additional instructions.

Reassembling the Machine

1. **Replace the bottom cover.** Replace the metal cover with the louvers pointing into the machine (see Figure 3). Insert and tighten the 12 screws. The four rubber feet are placed at the corners of the machine.
2. **Prepare the flexshaft assembly for re-insertion into the machine:** Gently pull the protruding flexshaft core (with squared end) out of the sheath several inches. Push the core back into the sheath and make sure that it slips into, and engages, the cutting motor. It will drop into the receptacle on the motor side about 5/8ths of an inch. Turn the core by hand and feel for resistance of the motor. If the shaft spins without resistance, push the core inward while rotating until it drops into the slot and engages the motor.
3. **Insert the flexshaft into cutting head:** Looking through the slot in the top cover, locate the flexshaft receptacle on the top of the Z-truck. Inside the receptacle there is a square recess that mates with the exposed square end of the flexshaft core. Turn the chuck on the bottom of the cutting head (open the safety cover for access) until the square core end can be inserted into the recess. Press the flex shaft all the way down into its receptacle. A click will be heard and felt as the shaft snaps into place.